

## Pump drives

**GB** Operator's manual

Translation of the original

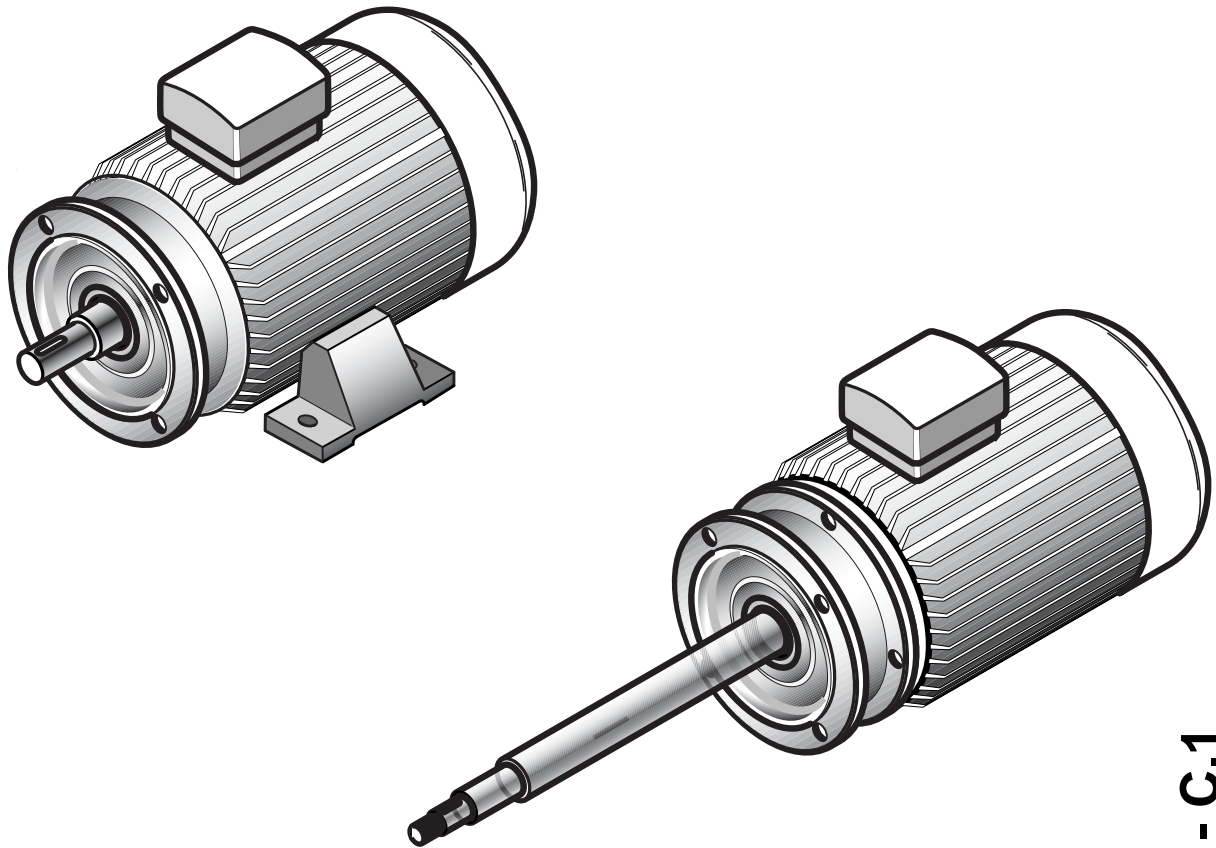

27217 - C.1

# Contents

|   | Page     |
|---|----------|
| <b>1 Safety Instructions .....</b>                    | <b>3</b> |
| 1.1 General .....                                     | 3        |
| 1.2 Symbols .....                                     | 3        |
| <b>2 Caution .....</b>                                | <b>3</b> |
| 2.1 General .....                                     | 3        |
| 2.2 Intended use .....                                | 3        |
| 2.3 Before you begin .....                            | 3        |
| 2.4 Preparation after extended storage .....          | 4        |
| <b>3 Installation of the drive .....</b>              | <b>4</b> |
| 3.1 Preparations .....                                | 4        |
| 3.2 Installation .....                                | 5        |
| <b>4 Electrical connection .....</b>                  | <b>5</b> |
| 4.1 General .....                                     | 5        |
| 4.2 Explosion-proof motors .....                      | 5        |
| <b>5 Start-up .....</b>                               | <b>6</b> |
| 5.1 General .....                                     | 6        |
| 5.2 Motor with pump .....                             | 6        |
| <b>6 Inspection and servicing .....</b>               | <b>6</b> |
| 6.1 Inspection & service intervals .....              | 6        |
| 6.2 Motor bearings .....                              | 6        |
| 6.3 Servicing .....                                   | 7        |
| <b>7 Error correction .....</b>                       | <b>8</b> |
| 7.1 Instructions for ordering replacement parts ..... | 10       |

## 1 Safety Instructions

### 1.1 General



#### **Warning!**

**Electrically live parts on electrical machines can cause severe or fatal injuries.**

**Installation, connection, startup and service and repair tasks may only be performed by qualified personnel, with attention to the following:**

- these instructions and the instructions for the centrifugal pump,
- the national and regional regulations currently in effect for safety and accident prevention on electric drives.
- Never put damaged drives into operation.
- Read these instructions carefully before beginning installation.
- It is imperative that you follow the safety advice contained in these instructions and in the instructions for the centrifugal pump.

### 1.2 Symbols

The following symbols are used in the text to call your attention to danger points.

**Symbol            Meaning:**



#### **Caution, risk of injury!**

This symbol warns you of danger from mechanical effects.



#### **Caution, risk of fatal injury!**

This symbol warns you of danger from electrical current.



This symbol warns you of actions which will damage or destroy the pump and/or drive.

## 2 Caution

### 2.1 General

These assembly and operating instructions refer exclusively to the special motors from Schmalenberger.

### 2.2 Intended use

The motors are used only as drives for the centrifugal pumps produced by Schmalenberger. The motors may not be utilized for other purposes.

Observance of the advice in these instructions and the associated operating instructions for the pump itself is requisite for trouble-free operation of the pump and fulfillment of any warranty claims.

The conformity and/or declarations of incorporation added to the pump instructions shall apply.

### 2.3 Before you begin

Install the drive only if you have checked:

- That the specifications on the model plate of the drive conform to your power grid.

- That the drive is undamaged; that is, that no damage was caused by transport or storage.

## 2.4 Preparation after extended storage

Examine the motor to see whether it has taken on moisture due to the long storage time. To do this, measure the insulation resistance.

The test voltage is 500V (see Fig. 1)

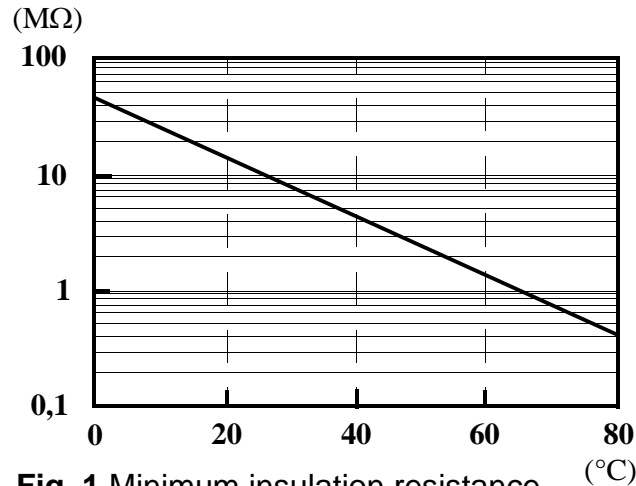

**Fig. 1** Minimum insulation resistance (°C)

The specifications refer to standard motors!

### Note

The insulation resistance is strongly dependent on the temperature! If the insulation resistance is too low, the motor must be dried.

To do this, heat the motor with warm air (80 °C max.). You can end the drying procedure when the minimum insulation resistance (see Fig. 1) is exceeded.

Check the terminal box to see whether:

- the interior is dry and clean
- connections and fasteners are corrosion-free
- the cover seal is intact
- the cable screw connections are tight.

If not, then dry, clean or replace the damaged parts.

## 3 Installation of the drive

### 3.1 Preparations

The motor is normally supplied complete with the front bearing ("A" side).

Clean the corrosion protection agent thoroughly from the shaft and shaft ends. Be sure that the solvent does not get into the bearings.

Clean the flange surfaces on the pump case and bearing skirt.

Check to be sure that the flange connection of the pump or bearing skirt and the drive motor match in size.

Check whether the protection class of the motor conforms to the requirements on site or of the system.

Uninstall the parts which are to be re-used from the old drive, such as the impeller, bearing ring seal, shaft protection sleeve, etc.

Examine all of the uninstalled parts which you intend to re-use for wear and visible damage. Replace defective parts with new ones.

### 3.2 Installation

Place the motor on the connecting flange of the pump case or the opposing flange of the bearing skirt. Be sure that it is correctly seated.

**Centering shoulder tolerance** of the flanges according to DIN 42948

- ISO j6 with  $\varnothing \leq 230$  mm
- ISO h6 with  $\varnothing > 230$  mm

Tightening the fastening screws evenly crosswise. The tightening torque depends on the screw diameter and should in no case be exceeded

#### Tightening torques for coarse pitch threads DIN 13

| Thread:    | Torque [Nm] for screws: |               |                       |
|------------|-------------------------|---------------|-----------------------|
|            | to plastic parts        | to cast parts | to bright steel parts |
| <b>M8</b>  | 7                       | 10 - 15       | 20                    |
| <b>M10</b> | 8                       | 25 - 35       | 40                    |
| <b>M12</b> | 10                      | 30 - 40       | 70                    |
| <b>M16</b> | --                      | 60 - 90       | 160                   |
| <b>M20</b> | --                      | 80 - 110      | --                    |

The figures apply to new, ungreased screws. The table values do not apply if deviating values are specified on the general diagrams or due to other instructions.

Install the parts which were removed from the old drive on the motor shaft. When doing so, follow the installation advice in the operating instructions for the pump = section „Repairs“.

After completing the installation check the free operation of the motor by hand by turning the impeller of the pump through the intake opening.

If this work is free of objection, the pump can again be installed in the pipeline system.

## 4 Electrical connection

### 4.1 General

It is essential that the following points be followed:

- If possible position the terminal box so that the cable entries point downward.
- Use only properly fitting screw cable connections and tighten them well;
- Clean sealing surfaces of terminal box and cover. Replace defective seals. Stick seals onto one side.
- When using motors with incorporated thermal motor protection, the cold contactors must always be connected. Otherwise the warranty will cease.

The motor must be connected in accordance with the accompanying circuit diagram. Screw down the cable connections and the ground wires tightly.

If possible use wire end ferrules without insulating material collars in accordance with DIN 46228, Part 1, material E-Cu.

### 4.2 Explosion-proof motors

Special features of explosion-protected motors(ignition protection type EExe and EExed)

For three-phase motors with current-dependent delayed protective device (with  $t_E$  time) use motor protective device with the following classification:

- according to DIN VDE 0660, PTB approved
- current-dependent delay.

For three-phase motors with direct temperature monitoring TF (with  $t_A$  time) with PTC thermistor temperature sensor in the winding, use triggering device with the following classification:

- PTB test mark 3.53 PTC A
- Response/shutoff time within the  $t_A$  time (see model plate of the motor).

## **5 Start-up**

### **5.1 General**

After making the connections and before starting up the motor make sure that the direction of rotation is correct.

Follow the specifications in the operating instructions for the centrifugal pump, section „**Electrical connection**“, topic: **Checking direction of rotation**.

### **5.2 Motor with pump**

The instructions given in the operating instructions for the centrifugal pump, section „**First-time start-up**“ apply to the start-up of the motor together with the centrifugal pump.

During start-up be certain that:

- the motor is running properly (speed variations, development of loud sounds, etc.),
- all of the motor protection devices are set to the rated current of the motor,
- the heating of the motor, especially at the bearings, does not exceed the maximum limit.

If problems should arise during start-up or during normal operation which do not come from the pump, follow the instructions in Chapter 7, Troubleshooting.

## **6 Inspection and servicing**

### **6.1 Inspection & service intervals**

The pump drives from the Schmalenberger company are largely maintenance-free. Depending on where they are used and the operating circumstances, however, monitoring is needed to maintain performance and prevent damage.

It is expedient to inspect the drive together with the centrifugal pump. Also see the operating instructions for the centrifugal pump, section „**Servicing & inspection**“.

The following checks and tasks should be performed at least monthly:

- Check heating of motor and bearings
- Remove soil from the cooling fins
- Functional check of the safety equipment

### **6.2 Motor bearings**

The service life of the motor bearings is significantly influenced by the operating conditions. The rule of thumb is:

every **10,000** hours of operation

- replace roller bearings
- replace shaft seals
- clean cooling air channels
- correct (renew) corrosion protection.

For motors starting with frame size 160 with AS- flanged bearing end housing  $\varnothing$  300 (applies to the single-race angular-contact ball bearings 7212 and 7310) the rule is:

every **4,000** hours of operation

- Re-grease the roller bearings in the AS flange with 15 g high-temperature grease (-40 - +180 °C, for example A72 Asonic).  
Re-grease using the grease fitting 636.

### 6.3 Servicing



#### **Caution!**

Before you begin any work on the motor the power to the motor must be switched off and secured against being switched on unintentionally.

#### 6.3.1 Changing bearings at the B end shield

To change the bearings in the B end shield proceed as follows:

- Remove fan hood, fan and tolerance ring.
- Remove tie rods or attaching screws, depending on motor size.
- Detach B end shield from stator.
- Pull B end shield off of motor shaft.
- Remove equalizing ring
- Uninstall defective bearing, clean B end shield and replace bearing with a new one. (For data see Chapter 8, Replacement parts).
- Clean all parts and reinstall in opposite order.
- Before installing the fan hood turn the fan wheel and check whether the motor and pump are running freely.



**Use only original replacement parts for the repairs!**

#### 6.3.2 Changing bearings at the A end shield

Bearing changes at the A end shield can only be done with the pump disassembled.

Follow the instructions and the procedure in **section „Repairs“** in the operating instructions for the centrifugal pump.

After the pump has been uninstalled and the impellor and shaft seal have been removed, the motor can be separated from the pump.

To replace the A side motor bearing proceed as follows:

- Dismount fan hood, fan and clearance ring.
- Remove tie rods or attaching screws, depending on motor size.
- Detach B end shield from stator.
- Pull B end shield off of motor shaft.
- Remove A end shield from stator.
- Pull A end shield off of motor shaft.
- Remove bearing cover / Seeger circlip ring in A end shield
- Pull A end shield off of motor shaft.
- Remove defective bearing, clean A end shield and replace bearing with a new one. (For data see Chapter 8, Replacement parts).
- Replace motor shaft seal.

- Clean stator winding, dry and check electrical characteristics (see section 2.3).
- Clean all other parts and reinstall in opposite order.
- Install the motor-pump unit according to the instructions in the operating instructions for the centrifugal pump section „**Repairs**“.
- Check for free movement of motor and pump.
- Install the pump in the pipeline system

**Note**

If you need help from our customer service department, prepare the following information:

- Power plate data, motor/pump no.:
- extent of the problem
- when and how did the problem arise
- the suspected cause.

Whenever you work on the motors from Schmalenberger, follow the recommendations and advice in the operating instructions.

Ask our customer service department for advice early, before starting tasks which are unclear to you!

**7 Error correction**

In order to determine and correct the causes of problems, in the following we enumerate the most frequent malfunctions and possible causes.

| <b>Problem</b>   | <b>Possible cause</b>  | <b>Solution</b>  |
|--|--|--|
| Motor does not start   | Power supply interrupted<br>Fuse defective<br>Motor protection triggered<br>Motor protection not switching, error in the controller  | Check connections, correct<br>Replace fuse<br>Check motor protection setting, correct if necessary<br>Check controller for motor protection, correct error as needed |
| Motor does not start or difficult to start                     | Motor designed for delta circuit, but terminals connected in star.<br>1 or 2 phases missing.<br>Voltage or frequency deviates greatly from rated value, at least when switched on. | Check and correct connection<br>Examine and correct line situation, check supply cross sections.   |
| Motor starts only with delta connection, not with star circuit | Too little torque with star connection<br>Contact fault on switch  | If delta circuit current not too high, switch on directly; otherwise check motor/pump design<br>Correct error  |
| Wrong direction of rotation                                    | Motor terminals connected wrong  | Reverse two phases in terminal box   |



| <b>Problem</b>                                | <b>Possible cause</b>   | <b>Solution</b>   |
|---|---|---|
| Motor hums and current draw is high           | Winding defective, rotor jamming<br>Pump sticking   | Take motor to a specialty shop for repairs  |
| Fuses or motor protection being triggered     | Short circuit in the supply line or in the motor<br>Supply line connected line<br>Short circuit to ground in the motor  | Correct short circuit; if in the motor, take to a specialty shop<br>Correct wiring<br>Have motor repaired in a specialty shop   |
| Drop in speed under load                      | Overloading of the motor<br>Voltage dropping  | Measure power; check motor & power design if appropriate<br>Increase cross section of supply line   |
| Motor gets too warm (Temperature measurement) | Overload<br>Insufficient cooling<br>Motor wired in delta instead of star<br>Supply line has contact problem (two-phase operation)<br>Fuse triggered<br>Line voltage varies from nominal rating by more than 10%<br>Nominal operating mode exceeded (S1 to S9, DIN 57530), for example by switching too frequently | Measure power; check motor & pump design if appropriate<br>Ambient temperature too high; clean cooling air passages<br>Correct wiring<br>Correct loose contact, re-tighten terminals<br>Replace fuse, find and correct cause<br>Using appropriate means, adjust line voltage to rated voltage of motor; change motor if necessary<br>Match nominal operating mode of the motor to the operating conditions; if necessary design a new drive |
| Motor noise too loud                          | Roller bearings soiled or defective<br>Vibration due to imbalance<br>Wear on the pump   | Check and/or replace roller bearings<br>Correct imbalance<br>General overhaul of motor and pump   |

## **8 List of replacement parts and drawing**

### **8.1 Instructions for ordering replacement parts**

1. When ordering replacement parts also note any special versions such as:

- low-noise, fan wheel dependent on direction of rotation
- other material for fan wheel or B side flange
- A side flange - own flanges for our HL model

The standard version illustrated may deviate from the delivered version. See your pump specification.

2. Special tool “BIT wrench” needed for tension bolt with self-locking serrations
3. Type NB - also applies to pump models FB, SM, WP
4. Type Z - also applies to pump models FZ, FZC, SZ

| Pos. | Size     | Type                | AS-flanged | Note<br>(on page 10) |  |
|------|----------|---------------------|------------|----------------------|--|
| 8.2  | 063      | ZH, Z, S            | ∅ 160      | 1 + 2 + 4            |  |
| 8.3  | 071      | ZH, Z               | ∅ 160      | 1 + 2 + 4            |  |
| 8.4  | 080      | ZH, Z, S            | ∅ 160      | 1 + 2 + 4            |  |
| 8.5  | 080      | NB                  | ∅ 185      | 1 + 2 + 3            |  |
| 8.6  | 090 L    | ZH, Z, S, NZ        | ∅ 160      | 1 + 2 + 4            |  |
| 8.7  | 090 L    | NB                  | ∅ 185      | 1 + 2 + 3            |  |
| 8.8  | 100 L    | ZH, Z, S, NZ        | ∅ 160      | 1 + 2 + 4            |  |
| 8.9  | 100 L    | NB                  | ∅ 185      | 1 + 2 + 3            |  |
| 8.10 | 112 M    | ZH, Z, S, NZ,<br>WP | ∅ 160      | 1 + 2 + 4            |  |
| 8.11 | 112 M    | NB                  | ∅ 185      | 1 + 2 + 3            |  |
| 8.12 | 132 S, M | NB                  | ∅ 185      | 1 + 2 + 3            |  |
| 8.13 | 132 S, M | ZH, Z, NZ           | ∅ 250      | 1 + 2 + 4            |  |
| 8.14 | 160 M, L | NB                  | ∅ 185      | 1 + 3                |  |
| 8.15 | 160 M    | ZH, Z, NZ           | ∅ 250      | 1 + 4                |  |
| 8.16 | 160 L    | ZH, NZ              | ∅ 300      | 1                    |  |
| 8.17 | 180 M, L | NB, ZH, NZ          | ∅ 300      | 1 + 3                |  |
| 8.18 | 200 L    | NB, ZH, NZ          | ∅ 300      | 1 + 3                |  |

**8.2 -  
8.13**

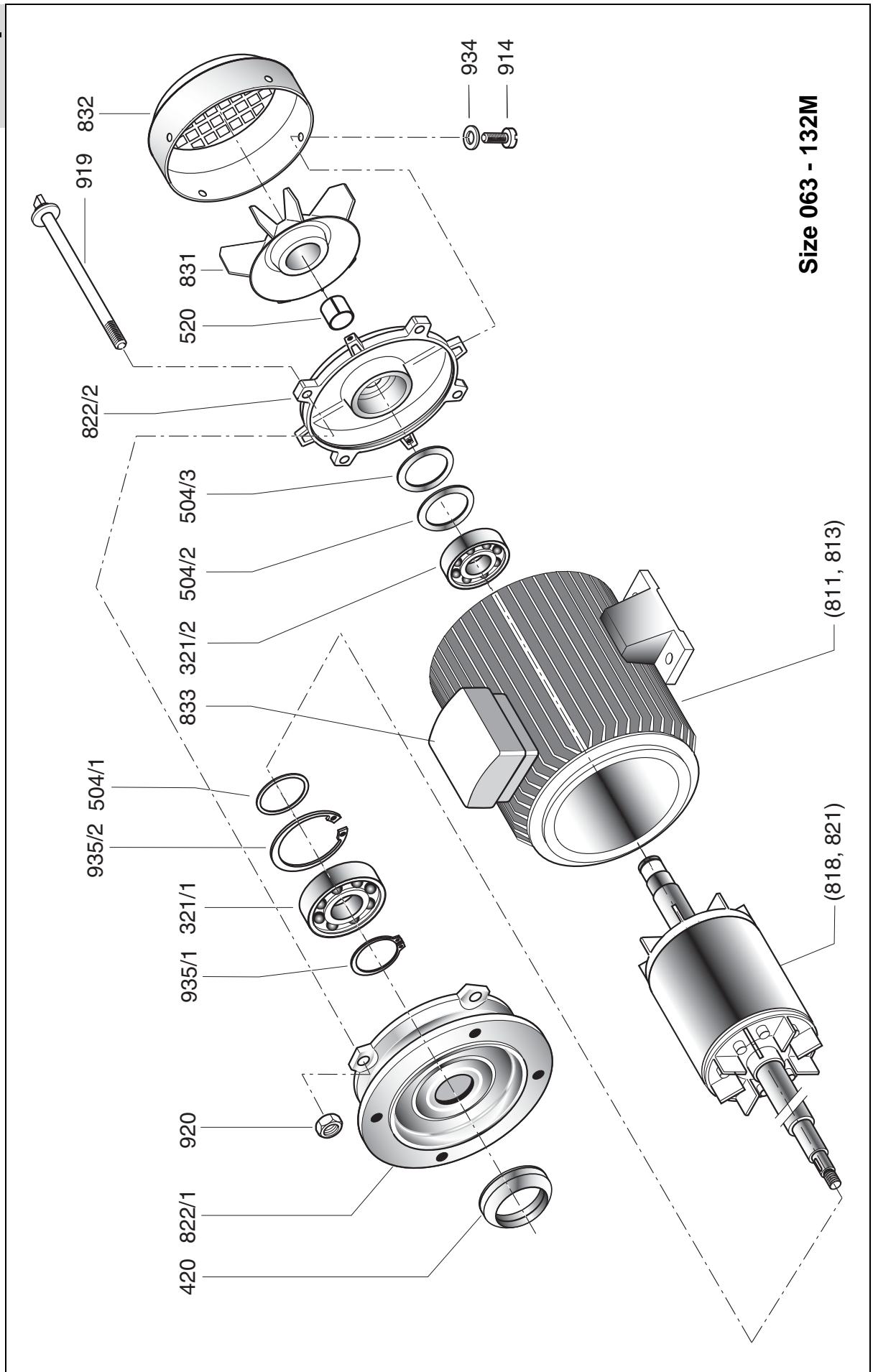

| Pos.:      | Qty.  | Designation                     | Note:                   |
|------------|-------|---------------------------------|-------------------------|
| 321/1      | 1     | Radial ball bearing             |                         |
| 321/2      | 1     | Radial ball bearing             |                         |
| 420        | 1     | Seal ring                       |                         |
| 504/1      | 1     | Supporting ring                 |                         |
| 504/2      | 1     | shim                            |                         |
| 504/3      | 1     | shim                            |                         |
| 520        | 1     | Tolerance sleeve                |                         |
| 811<br>813 | 1     | Motor frame with stator package |                         |
| 818        | 1     | Rotor                           |                         |
| 821        | 1     | Rotor package                   |                         |
| 822/1      | 1     | Flanged end plate AS            |                         |
| 822/2      | 1     | End plate BS                    |                         |
| 831        | 1     | Ventilator wheel                |                         |
| 832        | 1     | Ventilator cowl                 |                         |
| 833        | 1     | Conduit box                     |                         |
| 914        | 4/-   | Pan head                        |                         |
| 919        | 3/4   | Tension bolt                    | (See Note 2 on page 10) |
| 920        | 3/4/- | Hexagon head screw              |                         |
| 934        | 4/-   | Lock washer                     |                         |
| 935/1      | 1     | circlip ring                    |                         |
| 935/2      | 1     | circlip ring                    |                         |

8.14  
8.15

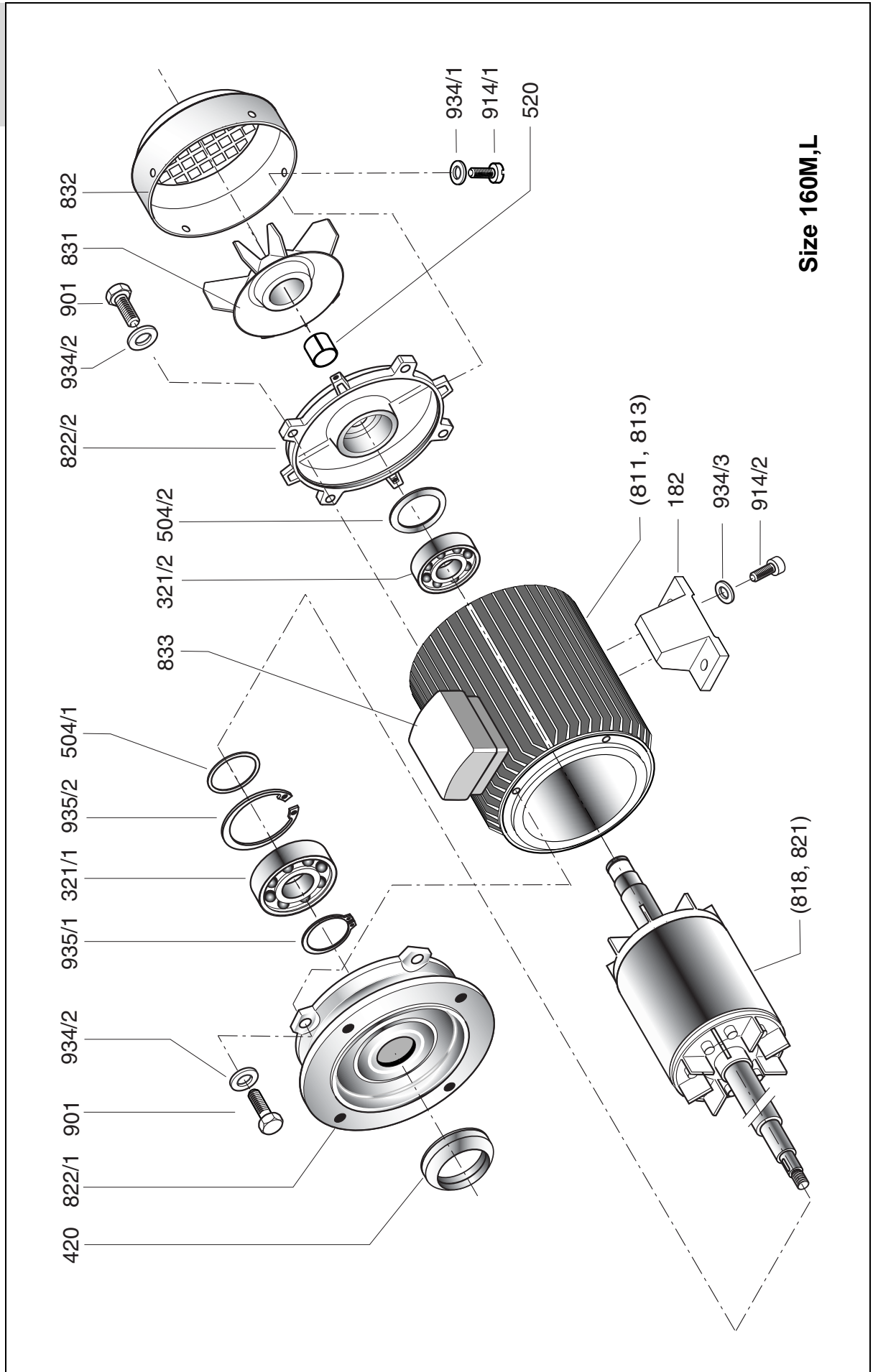

| Pos.:      | Qty. | Designation                      | Note: |
|------------|------|----------------------------------|-------|
| 182        | 2/-  | Motor base                       |       |
| 321/1      | 1    | Radial ball bearing              |       |
| 321/2      | 1    | Radial ball bearing              |       |
| 420        | 1    | Seal ring                        |       |
| 504/1      | 1    | Supporting ring                  |       |
| 504/2      | 1/2  | Ball bearing compensation washer |       |
| 520        | 1    | Tolerance sleeve                 |       |
| 811<br>813 | 1    | Motor case with stator package   |       |
| 818        | 1    | Rotor                            |       |
| 821        | 1    | Rotor package                    |       |
| 822/1      | 1    | Flanged end plate AS             |       |
| 822/2      | 1    | End plate BS                     |       |
| 831        | 1    | Ventilator wheel                 |       |
| 832        | 1    | Ventilator cowl                  |       |
| 833        | 1    | Conduit box                      |       |
| 901        | 8    | Hexagon head screw               |       |
| 914/1      | 4    | Pan head                         |       |
| 914/2      | 4    | Pan head                         |       |
| 934/1      | 4    | Lock washer                      |       |
| 934/2      | 8    | Lock washer                      |       |
| 934/3      | 4    | Lock washer                      |       |
| 935/1      | 1    | Seeger circlip ring              |       |
| 935/2      | 1    | Seeger circlip ring              |       |

**8.16**

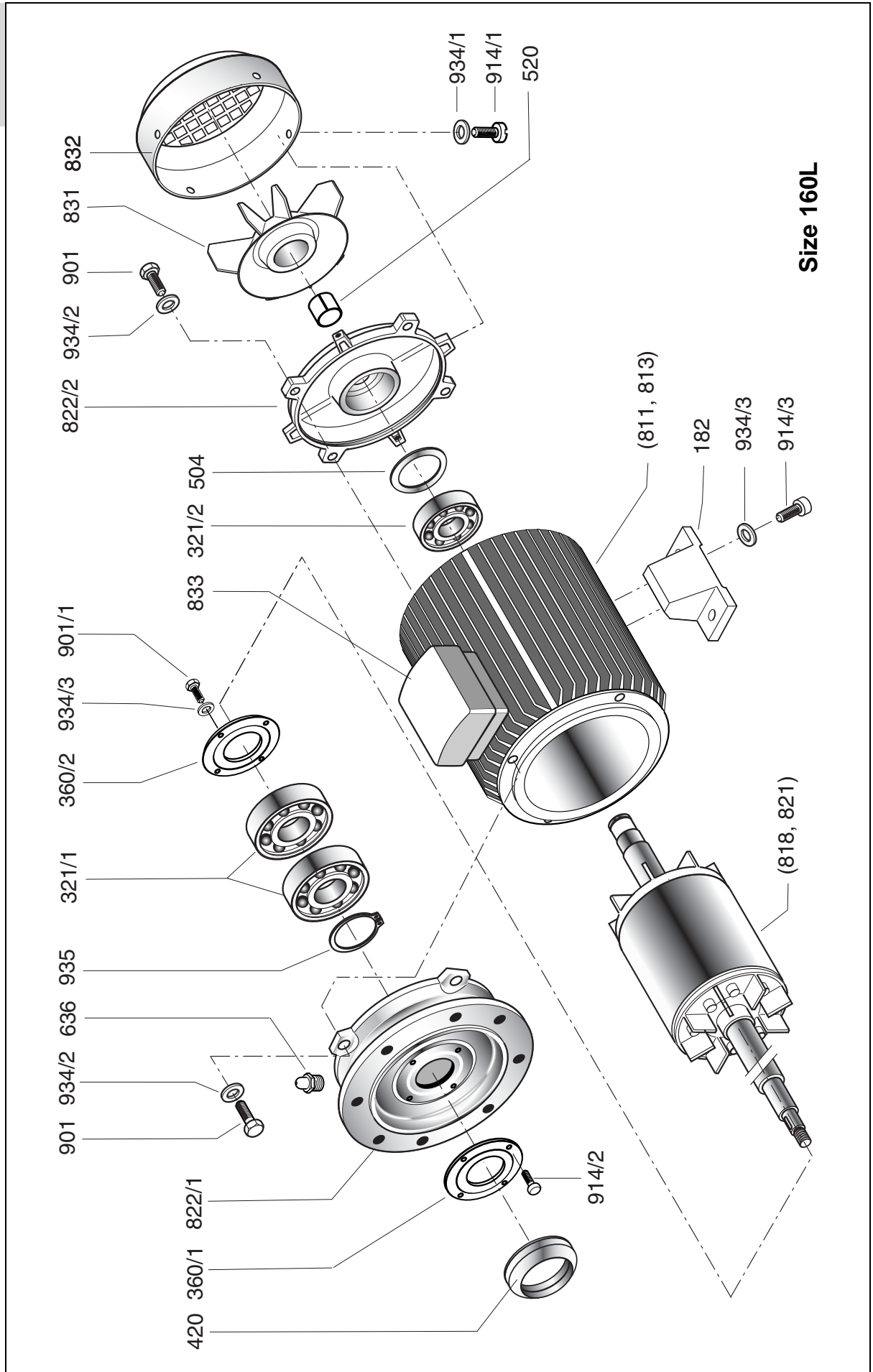

**Size 160L**



| <b>Pos.:</b> | <b>Qty.</b> | <b>Designation</b>               | <b>Note:</b> |
|--------------|-------------|----------------------------------|--------------|
| 182          | 2/-         | Motor base                       |              |
| 321/1        | 2           | Radial ball bearing              |              |
| 321/2        | 1           | Radial ball bearing              |              |
| 360/1        | 1           | Crown                            |              |
| 360/2        | 1           | Crown                            |              |
| 420          | 1           | Seal ring                        |              |
| 504          | 1           | Ball bearing compensation washer |              |
| 520          | 1           | Tolerance sleeve                 |              |
| 636          | 1           | Lubricating nipple               |              |
| 811<br>813   | 1           | Motor case with stator package   |              |
| 818          | 1           | Rotor                            |              |
| 821          | 1           | Rotor package                    |              |
| 822/1        | 1           | Flanged end plate AS             |              |
| 822/2        | 1           | End plate BS                     |              |
| 831          | 1           | Ventilator wheel                 |              |
| 832          | 1           | Ventilator cowl                  |              |
| 833          | 1           | Conduit box                      |              |
| 901          | 8           | Hexagon head screw               |              |
| 901/1        | 4           | Hexagon head screw               |              |
| 914/1        | 4           | Pan head                         |              |
| 914/2        | 4           | Pan head                         |              |
| 914/3        | 4/-         | Pan head                         |              |
| 934/1        | 4/-         | Lock washer                      |              |
| 934/2        | 8           | Lock washer                      |              |
| 934/3        | 4           | Lock washer                      |              |
| 935          | 1           | Seeger circlip ring              |              |

8.17  
8.18

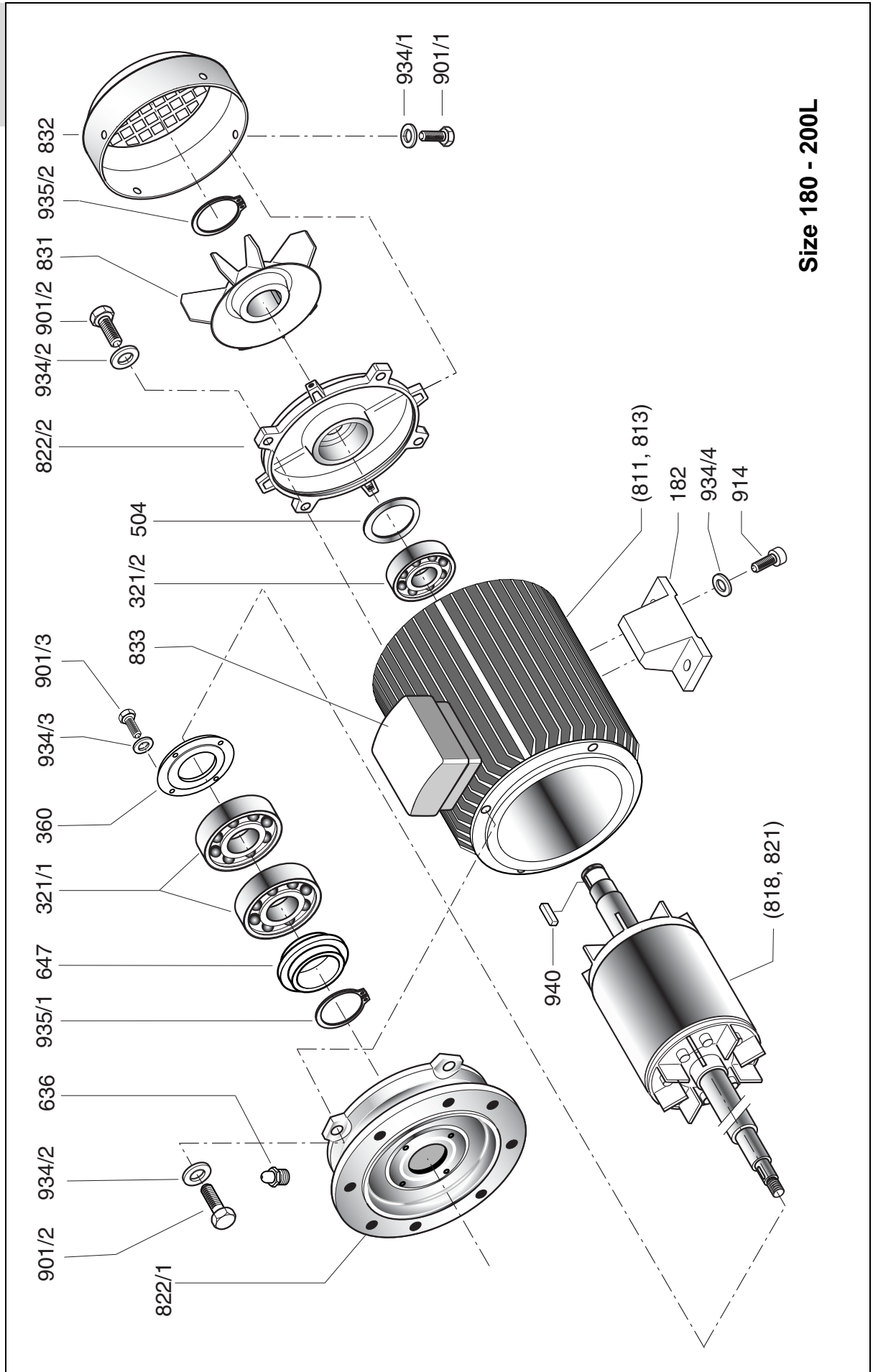

Size 180 - 200L

| <b>Pos.:</b> | <b>Qty.</b> | <b>Designation</b>               | <b>Note:</b> |
|--------------|-------------|----------------------------------|--------------|
| 182          | 2/-         | Motor base                       |              |
| 321/1        | 2           | Radial ball bearing              |              |
| 321/2        | 1           | Radial ball bearing              |              |
| 360          | 1           | Crown                            |              |
| 504          | 1           | Ball bearing compensation washer |              |
| 636          | 1           | Lubricating nipple               |              |
| 647          | 1           | Fat volume governor              |              |
| 811<br>813   | 1           | Motor case with stator package   |              |
| 818          | 1           | Rotor                            |              |
| 821          | 1           | Rotor package                    |              |
| 822/1        | 1           | Flanged end plate AS             |              |
| 822/2        | 1           | End plate BS                     |              |
| 831          | 1           | Ventilator wheel                 |              |
| 832          | 1           | Ventilator cowl                  |              |
| 833          | 1           | Conduit box                      |              |
| 901/1        | 4           | Hexagon head screw               |              |
| 901/2        | 8/4         | Hexagon head screw               |              |
| 901/3        | 4           | Hexagon head screw               |              |
| 914          | 4/-         | Pan head                         |              |
| 934/1        | 4           | Lock washer                      |              |
| 934/2        | 8/-         | Lock washer                      |              |
| 934/3        | 4           | Lock washer                      |              |
| 934/4        | 4           | Lock washer                      |              |
| 935/1        | 1           | Seeger circlip ring              |              |
| 935/2        | 1           | Seeger circlip ring              |              |
| 940          | 1           | Feather key                      |              |

**Schmalenberger GmbH + Co. KG**

Strömungstechnologie

Im Schelmen 9 - 11

D-72072 Tübingen / Germany

Telefon: +49 (0)7071 70 08 - 0

Telefax: +49 (0)7071 70 08 - 14

Internet: [www.schmalenberger.de](http://www.schmalenberger.de)

E-Mail: [info@schmalenberger.de](mailto:info@schmalenberger.de)

© 2018 Schmalenberger GmbH + Co. KG ; All Rights reserved

This document is subject to change without notice

Pump drives

Version: 27217 - C